

ASCENDO

Vertical Sliding System
Giyotin Sistem



Technical Brochure | Teknik Broşür

www.aluarc.com

AluArc[®]
Aluminium Systems

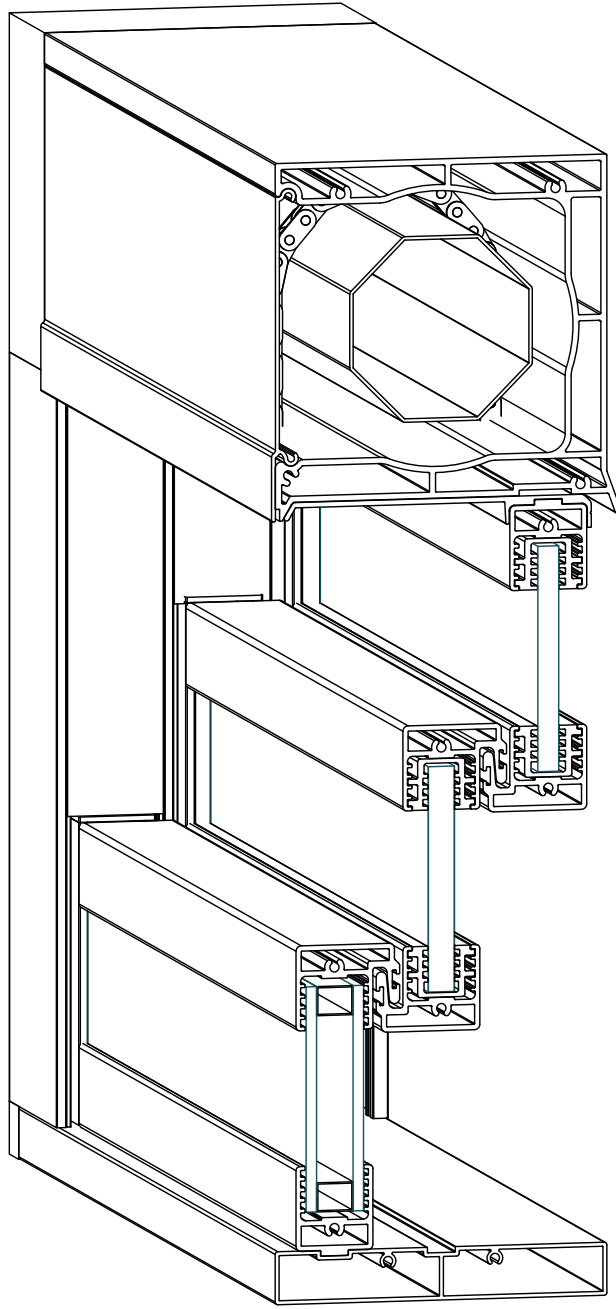

Vertical Sliding System / Giyotin Sistem

ASCENDO



ASCENDO Profile Technical Properties / Profil Teknik Özellikleri

Bottom Profile / Alt Kasa Profil	127 x 20 mm
Wall Thickness of Bottom Profile / Alt Kasa Profili Et Kalınlığı	1,5 mm
Top Profile / Üst Kasa Profili	127 x 123 mm
Wall Thickness of Top Profile / Üst Kasa Et Kalınlığı	2,3 mm
Bottom Panel Profile / Alt Baza Profili	29 x 34 mm
Wall Thickness of Bottom Panel Profile / Alt Baza Profili Et Kalınlığı	2 mm
Side Panel Profile / Yan Baza Profili	29 x 33 mm
Wall Thickness of Side Panel Profile / Yan Baza Profili Et Kalınlığı	3 mm

ASCENDO Technical Properties Roof / Çatı Teknik Özellikleri

System Height / Sistem Yüksekliği	3000 mm
Panel Width / Panel Geniřlięi	4000 mm
Glass Thickness / Cam Kalınlığı	22 mm Double Glass / Isıcam
Glass Type / Cam Tipi	Tempered / Laminated
Profile Colors (In Stock) / Profil Renkleri (Stokta)	Press / Ham
Panel Cap Colours (In Stock) / Panel Kapak Renkleri (Stokta)	Grey,Black / Gri, Siyah

ASCENDO Profiles / Profiller



Ölçü / Scale: 1/2

Vertical Sliding System / Giyotin Sistem

ASCENDO

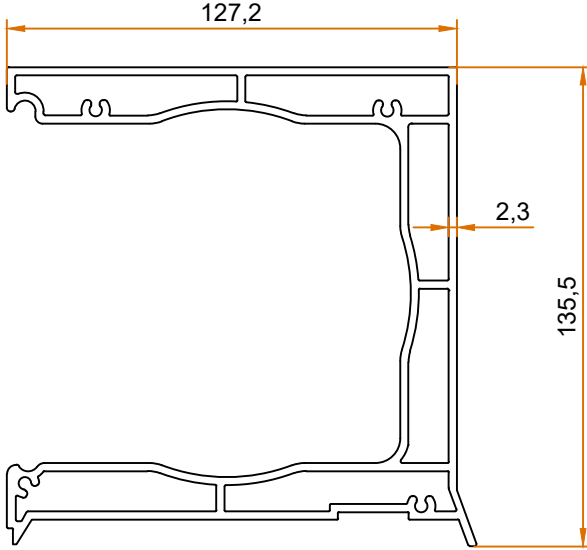

Profile Name: / Profil İsim:

Top Profil / Üst Profili

Code Nr.: / Kod No.:

16 01 01 10

Weight kg/m: / Ağırlık

5.333

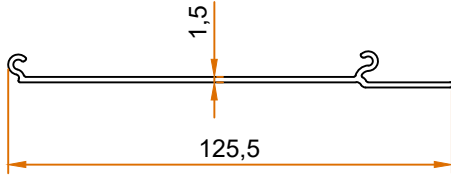

Profile Name: / Profil İsim:

Side Frame Cap / Kapak Profili

Code Nr.: / Kod No.:

16 01 01 11

Weight kg/m: / Ağırlık

0.600

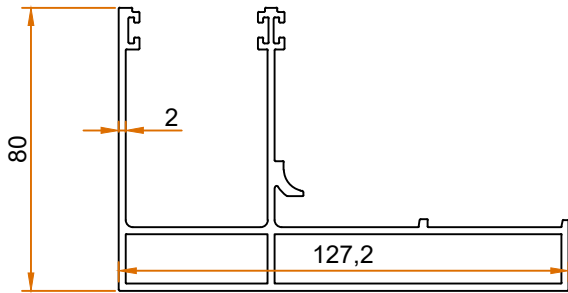

Profile Name: / Profil İsim:

Side Frame Profile / Yan Kasa Profili

Code Nr.: / Kod No.:

16 01 01 12

Weight kg/m: / Ağırlık

2.500

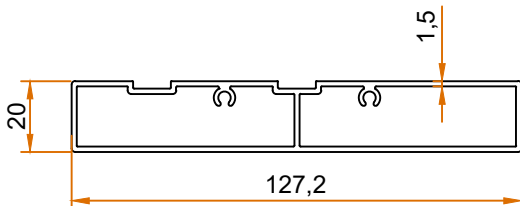

Profile Name: / Profil İsim:

Bottom Profile / Alt Kasa Profili

Code Nr.: / Kod No.:

16 01 01 13

Weight kg/m: / Ağırlık

0.750

ASCENDO Profiles / Profiller



Ölçü / Scale: 1/2

Vertical Sliding System / Giyotin Sistem

ASCENDO

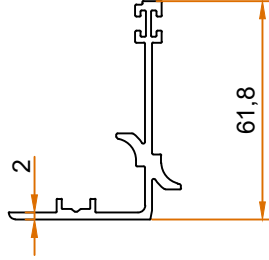

Profile Name: / Profil İsim:

Side Frame Profil / Yan Kızak Profili

Code Nr.: / Kod No.:

16 01 01 14

Weight kg/m: / Ağırlık

0.883

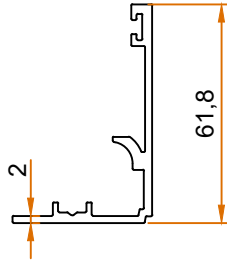

Profile Name: / Profil İsim:

Side Frame Profil / Yan Kızak Profili

Code Nr.: / Kod No.:

16 01 01 15

Weight kg/m: / Ağırlık

0.866

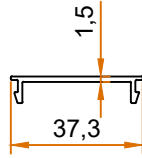

Profile Name: / Profil İsim:

Side Frame Cap Profil / Yan Kasa Kızak Profili

Code Nr.: / Kod No.:

16 01 01 16

Weight kg/m: / Ağırlık

0.200

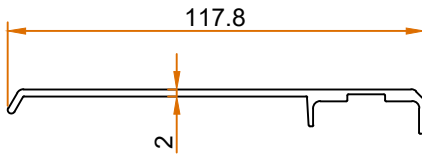

Profile Name: / Profil İsim:

Railing Profile / Küpeşte Profili

Code Nr.: / Kod No.:

16 01 01 17

Weight kg/m: / Ağırlık

0.800

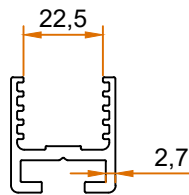

Profile Name: / Profil İsim:

Side Panel Profile / Yan Baza

Code Nr.: / Kod No.:

16 01 01 18

Weight kg/m: / Ağırlık

0.766

ASCENDO Profiles / Profiller



Ölçü / Scale: 1/2

Vertical Sliding System / Giyotin Sistem

ASCENDO

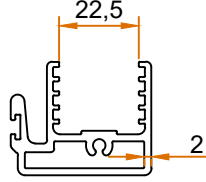

Profile Name: / Profil İsim:

Pull Profil / Çekme Profili

Code Nr.: / Kod No.:

16 01 01 19

Weight kg/m: / Ağırlık

1.000

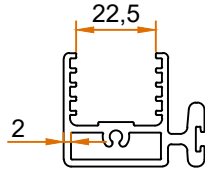

Profile Name: / Profil İsim:

Up Pull Profile / Yukarı Çekme Profil

Code Nr.: / Kod No.:

16 01 01 20

Weight kg/m: / Ağırlık

1.010

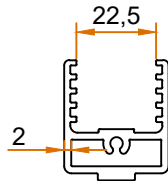

Profile Name: / Profil İsim:

Bottom Panel Profil / Alt Baza Profili

Code Nr.: / Kod No.:

16 01 01 21

Weight kg/m: / Ağırlık

0.800

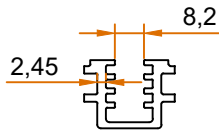

Profile Name: / Profil İsim:

8mm Panel Profile / 8mm Baza Profil

Code Nr.: / Kod No.:

16 01 01 22

Weight kg/m: / Ağırlık

0.483

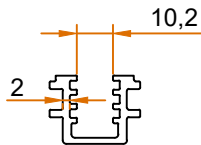

Profile Name: / Profil İsim:

10mm Panel Profile / 10mm Baza Profil

Code Nr.: / Kod No.:

16 01 01 23

Weight kg/m: / Ağırlık

0.480

ASCENDO Accessory / Aksesuar



Scale / Ölçü: 1/2

Vertical Sliding System / Giyotin Sistem

ASCENDO



Profile Name: / Profil İsim:

Panel Profile Cap / Baza Kapağı

Code Nr.: / Kod No.:

16 03 08 10

Material / Malzeme:

Polyamide / Polyamid

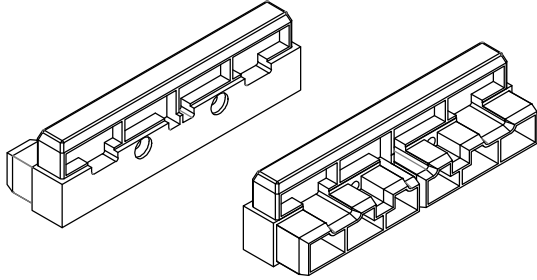

Profile Name: / Profil İsim:

Bottom Bağlantı / Alt Bağlantı

Code Nr.: / Kod No.:

16 03 08 11

Material / Malzeme:

Polyamide / Polyamid

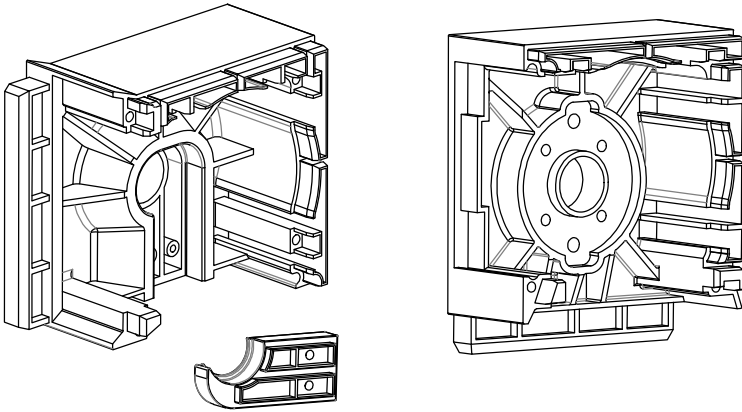

Profile Name: / Profil İsim:

Motor Bock Cap Set / Motor Blok Seti

Code Nr.: / Kod No.:

16 03 08 12

Material / Malzeme:

Polyamide / Polyamid

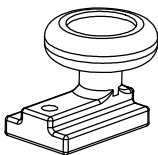

Profile Name: / Profil İsim:

Guide Wheel / Tek Teker

Code Nr.: / Kod No.:

16 03 10 10

Material / Malzeme:

Zamac / Zamak

ASCENDO Accessory / Aksesuar



Scale / Ölçü: 1/2

Vertical Sliding System / Giyotin Sistem

ASCENDO

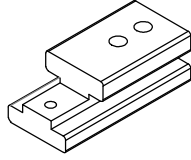

Profile Name: / Profil İsim:

Chain Connect / Zincir Balatı

Code Nr.: / Kod No.:

16 01 01 24

Material / Malzeme:

Aluminium / Aüminyum

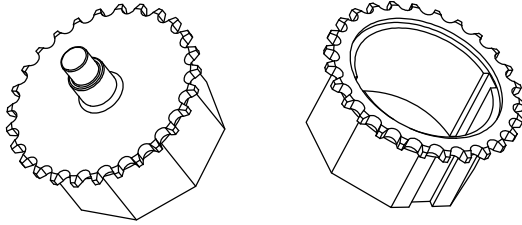

Profile Name: / Profil İsim:

Chain Gear Set / Zincir Dişli Seti

Code Nr.: / Kod No.:

16 03 03 10

Material / Malzeme:

Steel / Çelik



Profile Name: / Profil İsim:

Chain 3,8 / Zincir 3,8

Code Nr.: / Kod No.:

16 03 03 11

Material / Malzeme:

Steel / Çelik

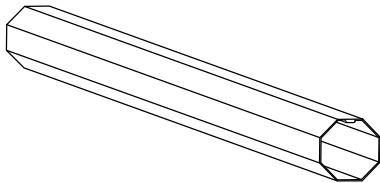

Profile Name: / Profil İsim:

Motor Barrel / Tamburu

Code Nr.: / Kod No.:

16 03 03 12

Material / Malzeme:

Steel / Çelik

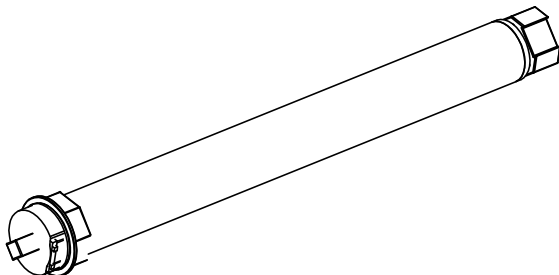

Profile Name: / Profil İsim:

Tub Motor Set / Tüp Motor Seti

Code Nr.: / Kod No.:

16 03 11 10

Company / Firma

BECKER 120 N/m inc. Remote Control

ASCENDO Accessory / Aksesuar



Scale / Ölçü: 1/2

Vertical Sliding System / Giyotin Sistem

ASCENDO

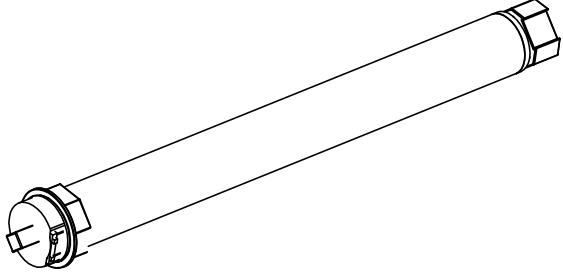

Profile Name: / Profil İsim:

Tub Motor Set / Tüp Motor Seti

Code Nr.: / Kod No.:

16 03 11 11

Company / Firma

BECKER 80 N/m inc. Remote Control

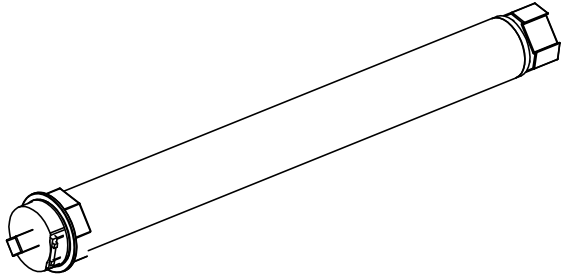

Profile Name: / Profil İsim:

Tub Motor Set / Tüp Motor Seti

Code Nr.: / Kod No.:

16 03 11 12

Company / Firma

SOMPFY 120 N/m inc. Remote Control

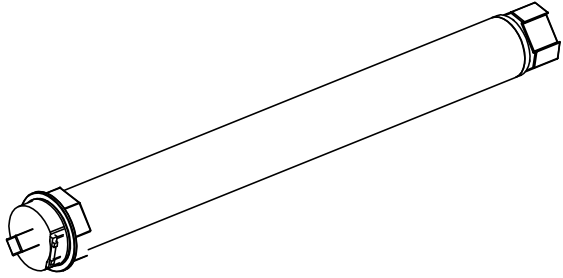

Profile Name: / Profil İsim:

Tub Motor Set / Tüp Motor Seti

Code Nr.: / Kod No.:

16 03 11 13

Company / Firma

SOMPFY 80 N/m inc. Remote Control

ASCENDO Accessory / Aksesuar



Scale / Ölçü: 1/2

Vertical Sliding System / Giyotin Sistem

ASCENDO

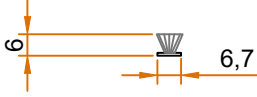

Name: / İsim:

Side Jump Brush Film / Yan Kasa Kıl Fitol Filmli

Code Nr.: / Kod No.:

16 05 07 10

Material / Malzeme:

PVC

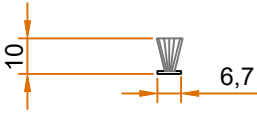

Name: / İsim:

Side Jump Brush Film / Yan Kasa Kıl Fitol Filmli

Code Nr.: / Kod No.:

16 05 07 11

Material / Malzeme:

PVC

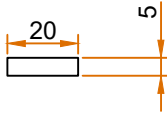

Name: / İsim:

Top Profile Gasket / Üst Kasa Fitol

Code Nr.: / Kod No.:

16 05 09 10

Material / Malzeme:

Rubber / Kauçuk

Name: / İsim:

Code Nr.: / Kod No.:

Material: / Malzeme:

Name: / İsim:

Code Nr.: / Kod No.:

Material: / Malzeme:

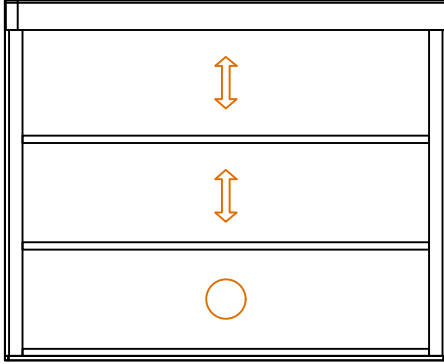

3 Elements at Bottom Stacking System /
3 Parça Alta Toplanan Sistem

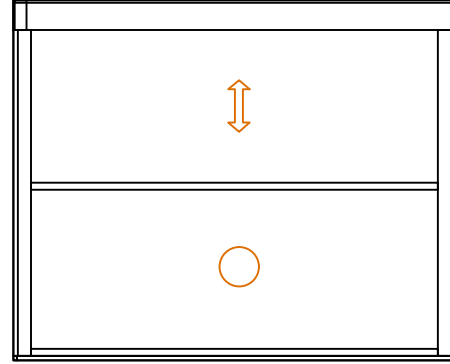

2 Elements at Bottom Stacking System /
2 Parça Alta Toplanan Sistem

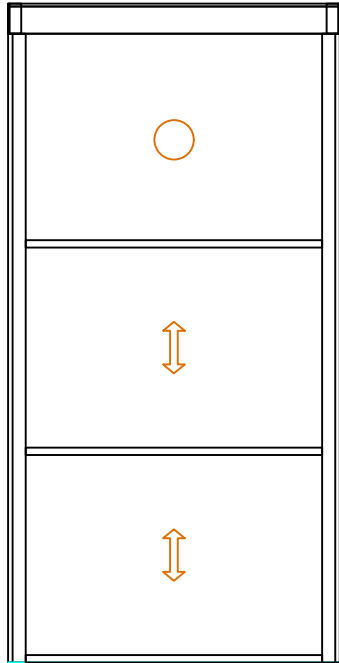

3 Elements at Top Stacking System /
3 Parça Üste Toplanan Sistem

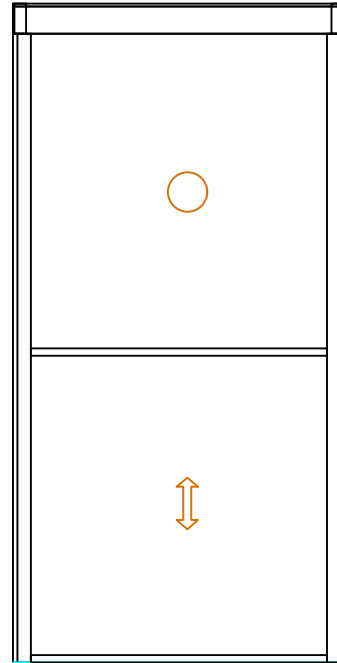

2 Elements at Top Stacking System /
2 Parça Üste Toplanan Sistem

ASCENDO Section / Kesit



Scale / Ölçü: 1/2

Vertical Sliding System / Giyotin Sistem

ASCENDO

3 Elements Gathering Down System /
3 Parça Alta Toplanan Sistem

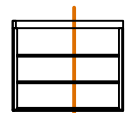
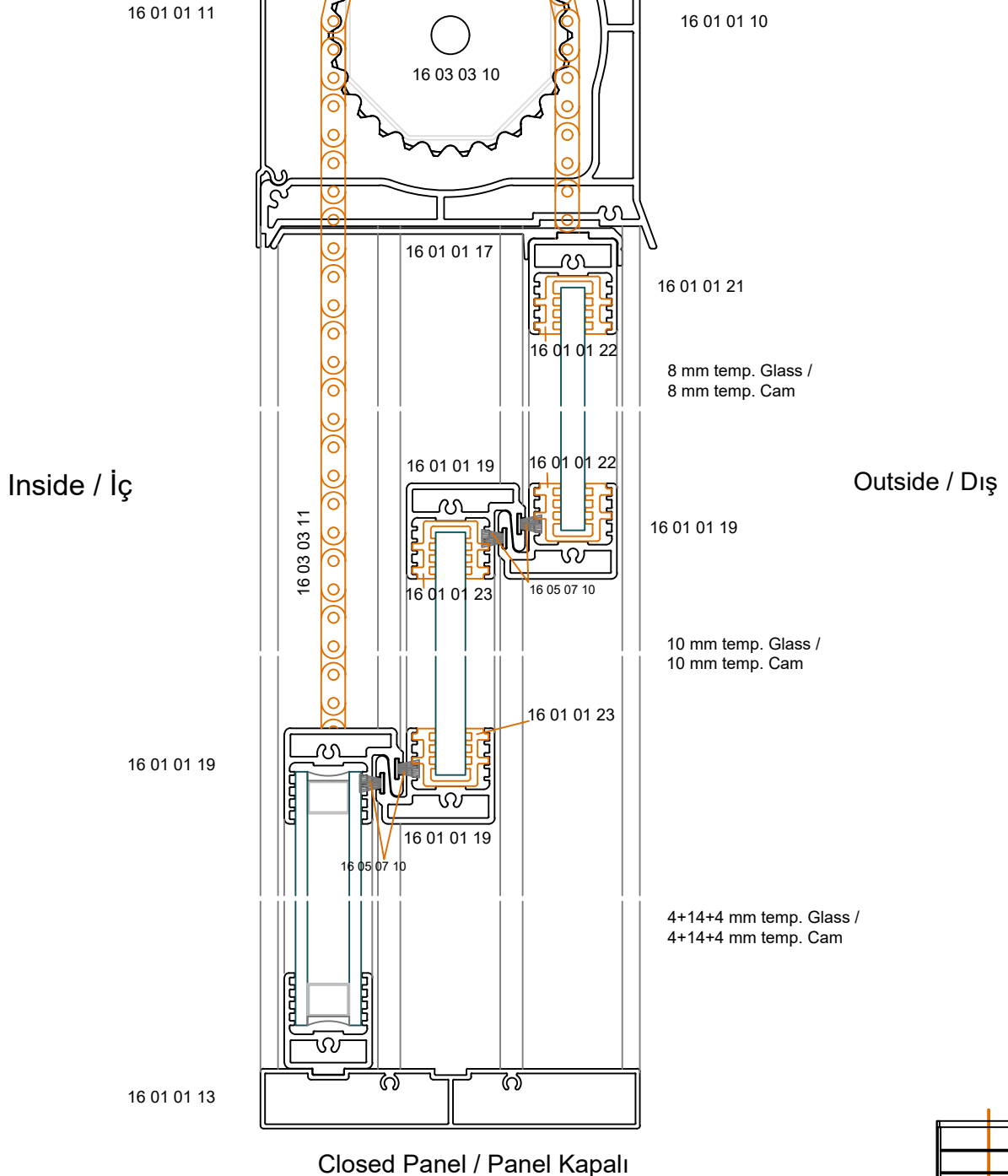

kesit / section

ASCENDO Section / Kesit



Scale / Ölçü: 1/2

Vertical Sliding System / Giyotin Sistem

ASCENDO

3 Elements Gathering Down System /
3 Parça Alta Toplanan Sistem

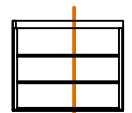
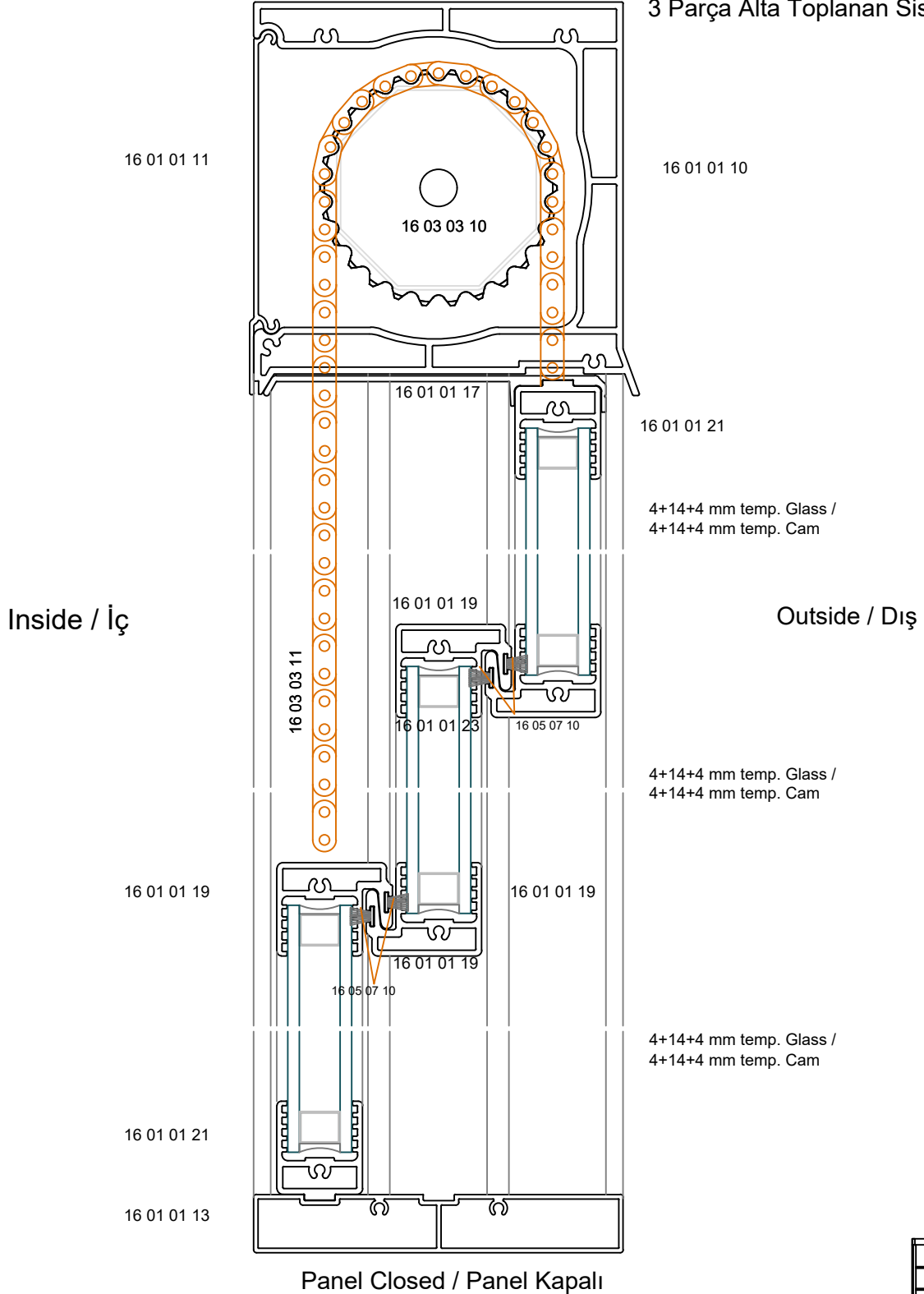

kesit / section

ASCENDO Section / Kesit



Scale / Ölçü: 1/2

Vertical Sliding System / Giyotin Sistem

ASCENDO

3 Elements Gathering Down System /
3 Parça Alta Toplanan Sistem

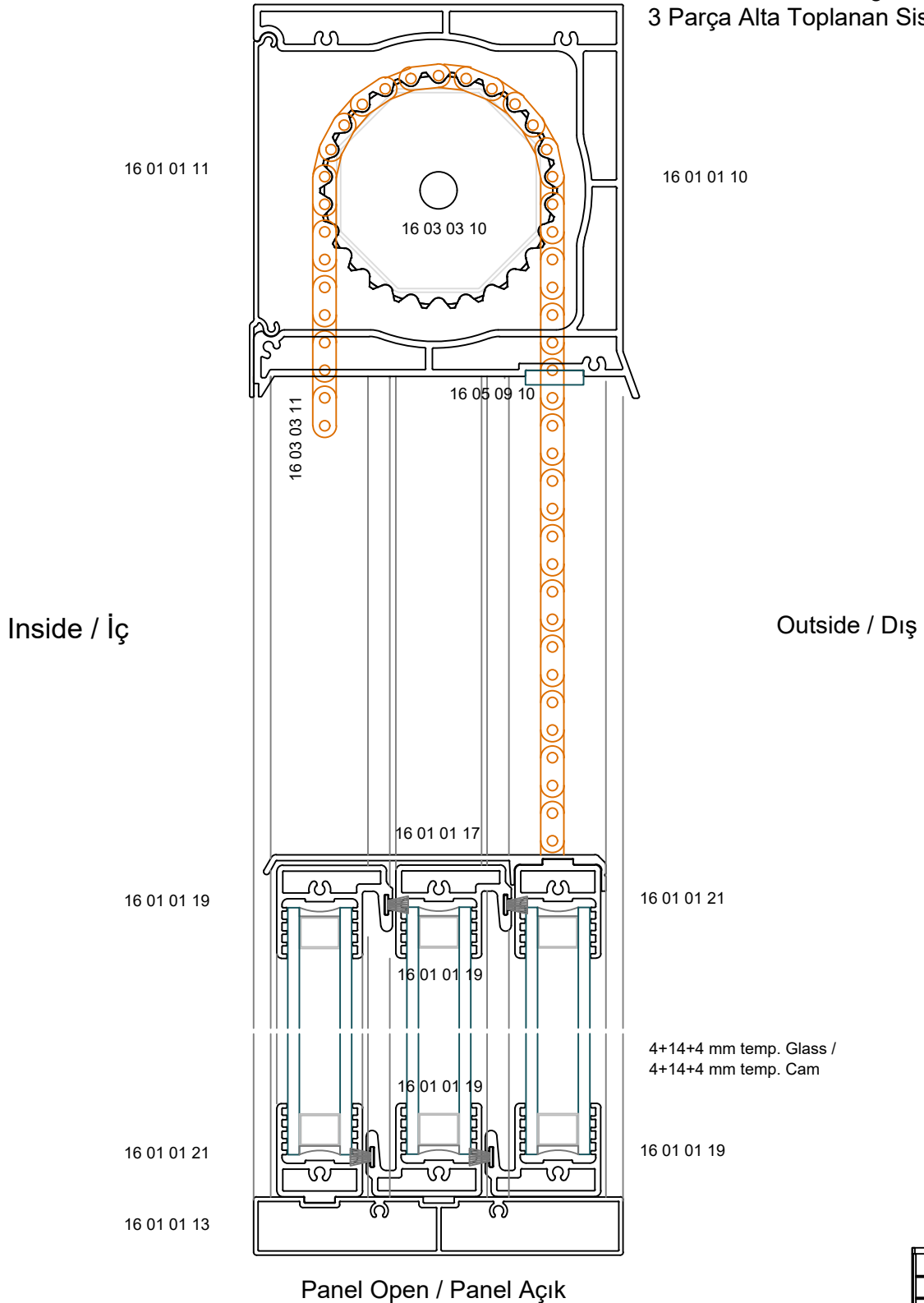

ASCENDO Top Section / Üst Kesit



Scale / Ölçü: 1/2

Vertical Sliding System / Giyotin Sistem

ASCENDO

3 Elements Gathering Down System /
3 Parça Alta Toplanan Sistem

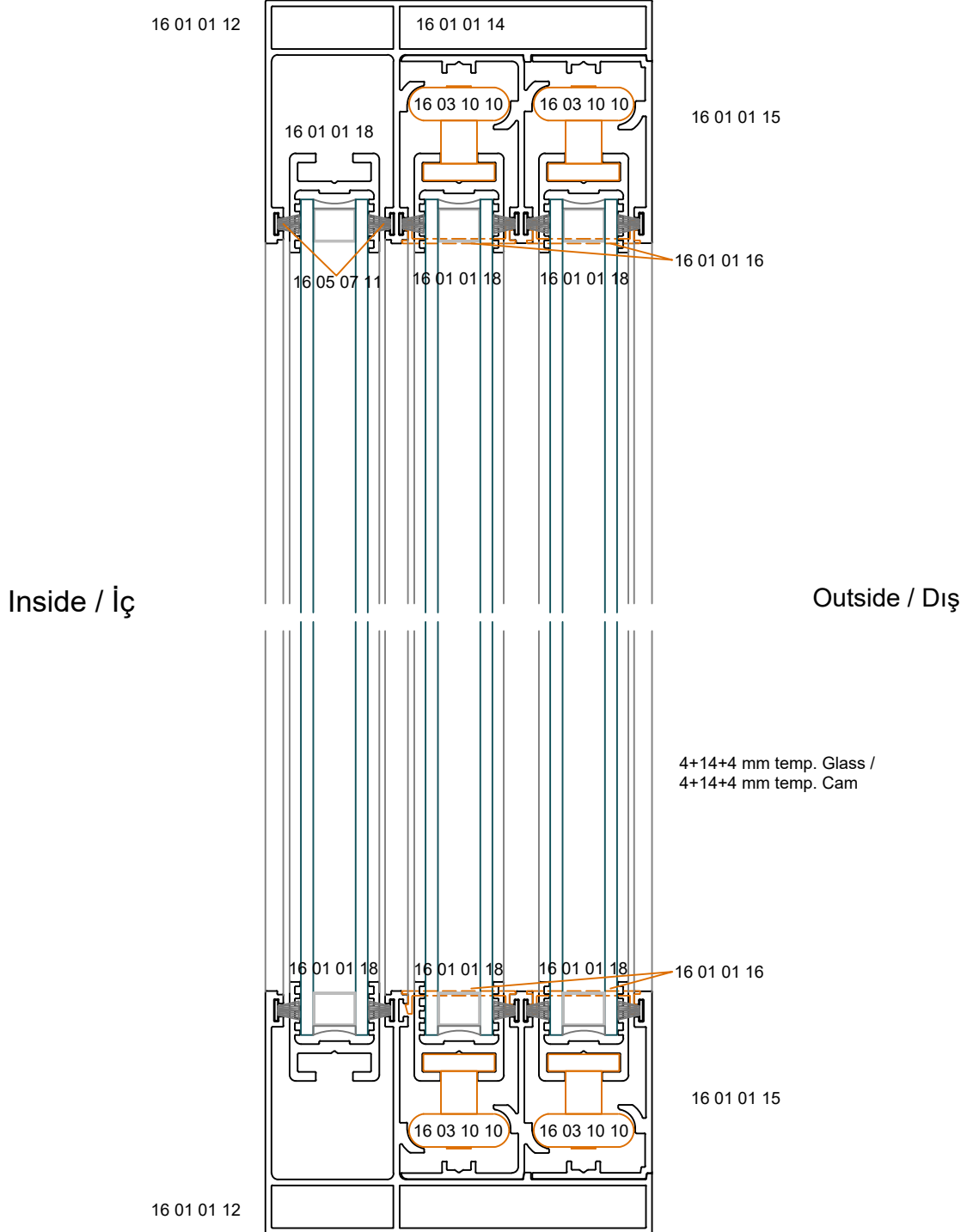

ASCENDO Section / Kesit

Scale / Ölçü: 1/2

Vertical Sliding System / Giyotin Sistem

ASCENDO

2 Elements at Bottom Stacking System /
2 Parça Alta Toplanan Sistem

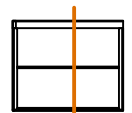
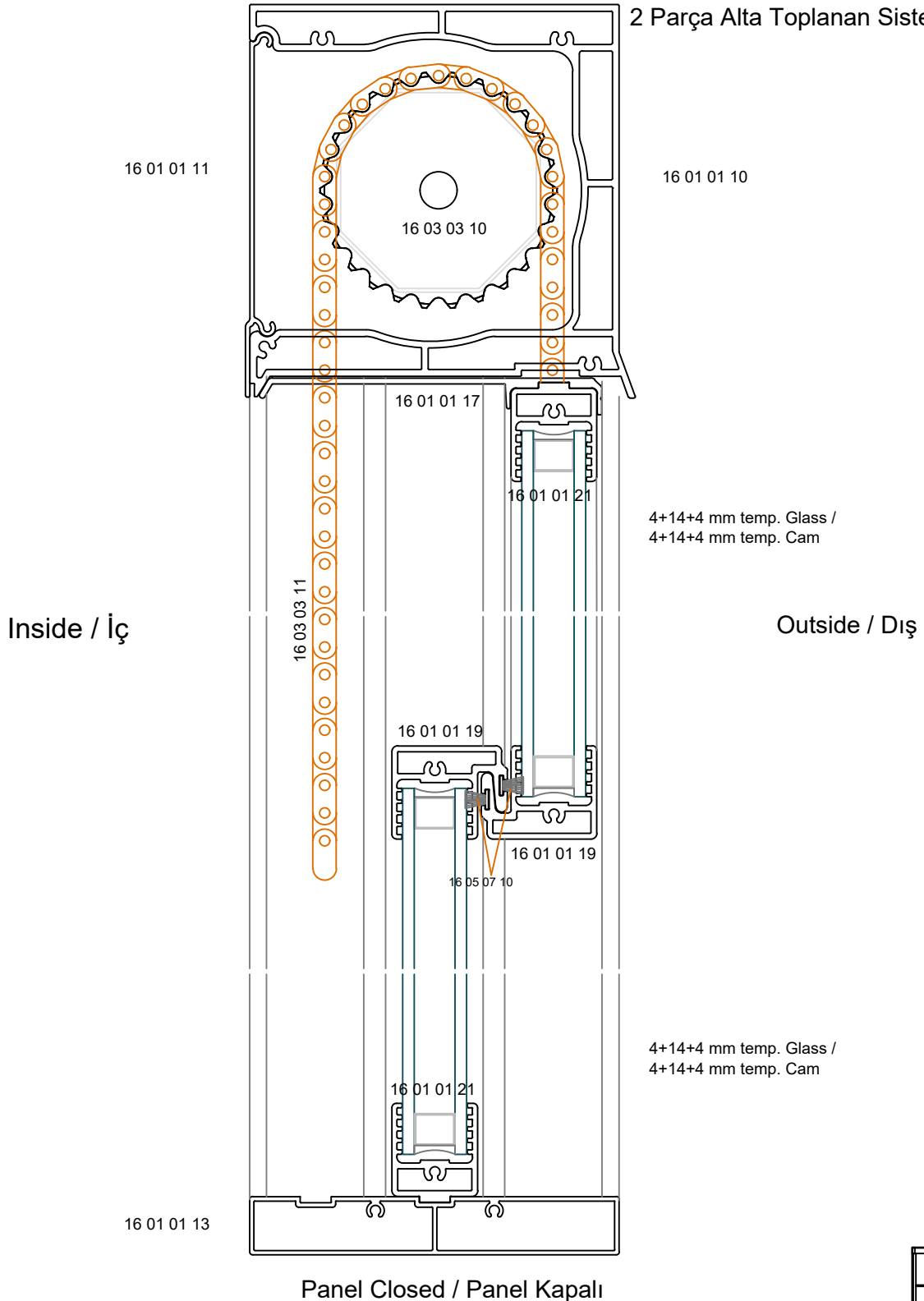

kesit / section

ASCENDO Section / Kesit



Scale / Ölçü: 1/2

Vertical Sliding System / Giyotin Sistem

ASCENDO

2 Elements at Bottom Stacking System /
2 Parça Alta Toplanan Sistem

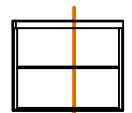
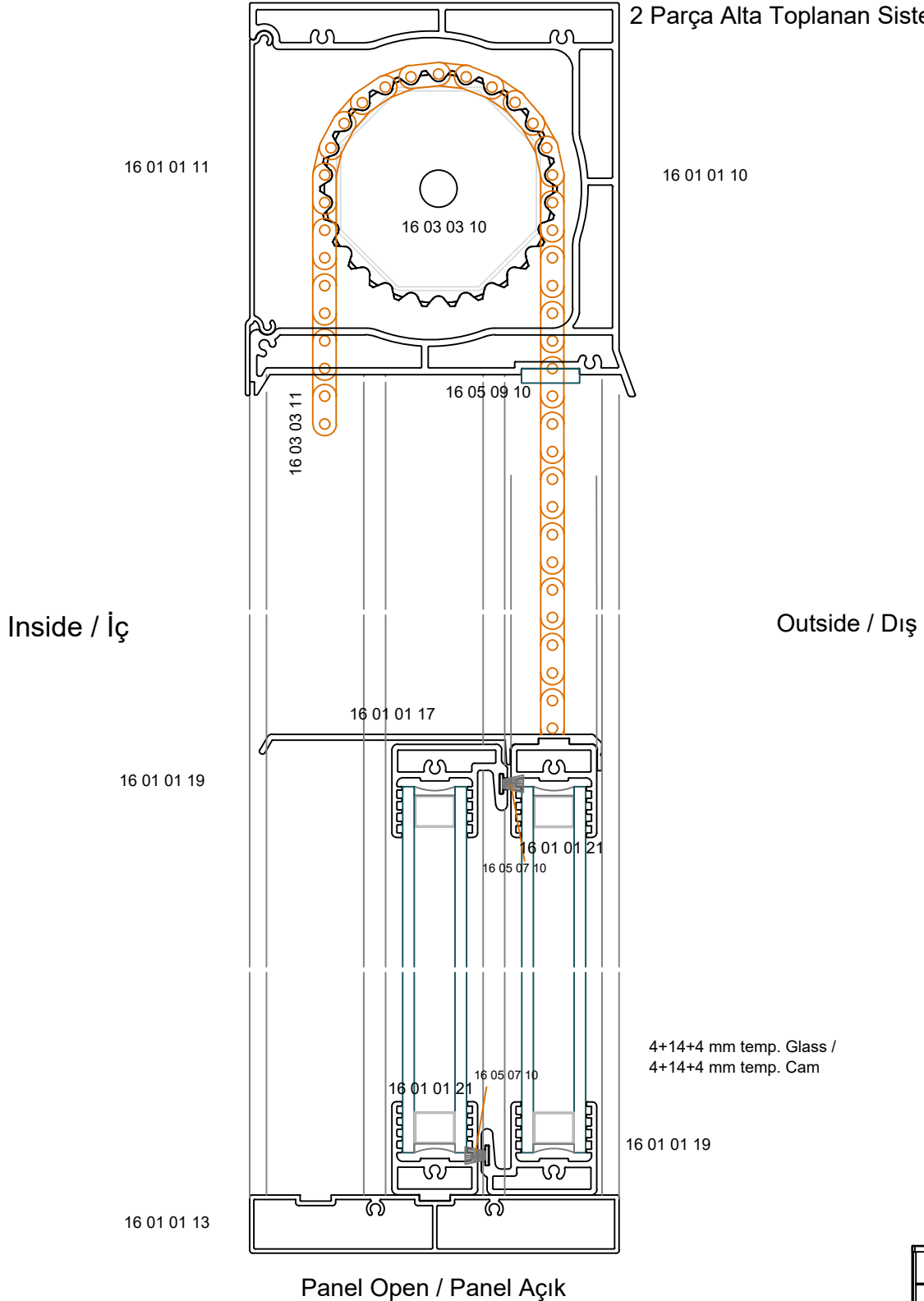

kesit / section

ASCENDO Top Section / Üst Kesit



Scale / Ölçü: 1/2

Vertical Sliding System / Giyotin Sistem

ASCENDO

2 Elements at Bottom Stacking System /
2 Parça Alta Toplanan Sistem

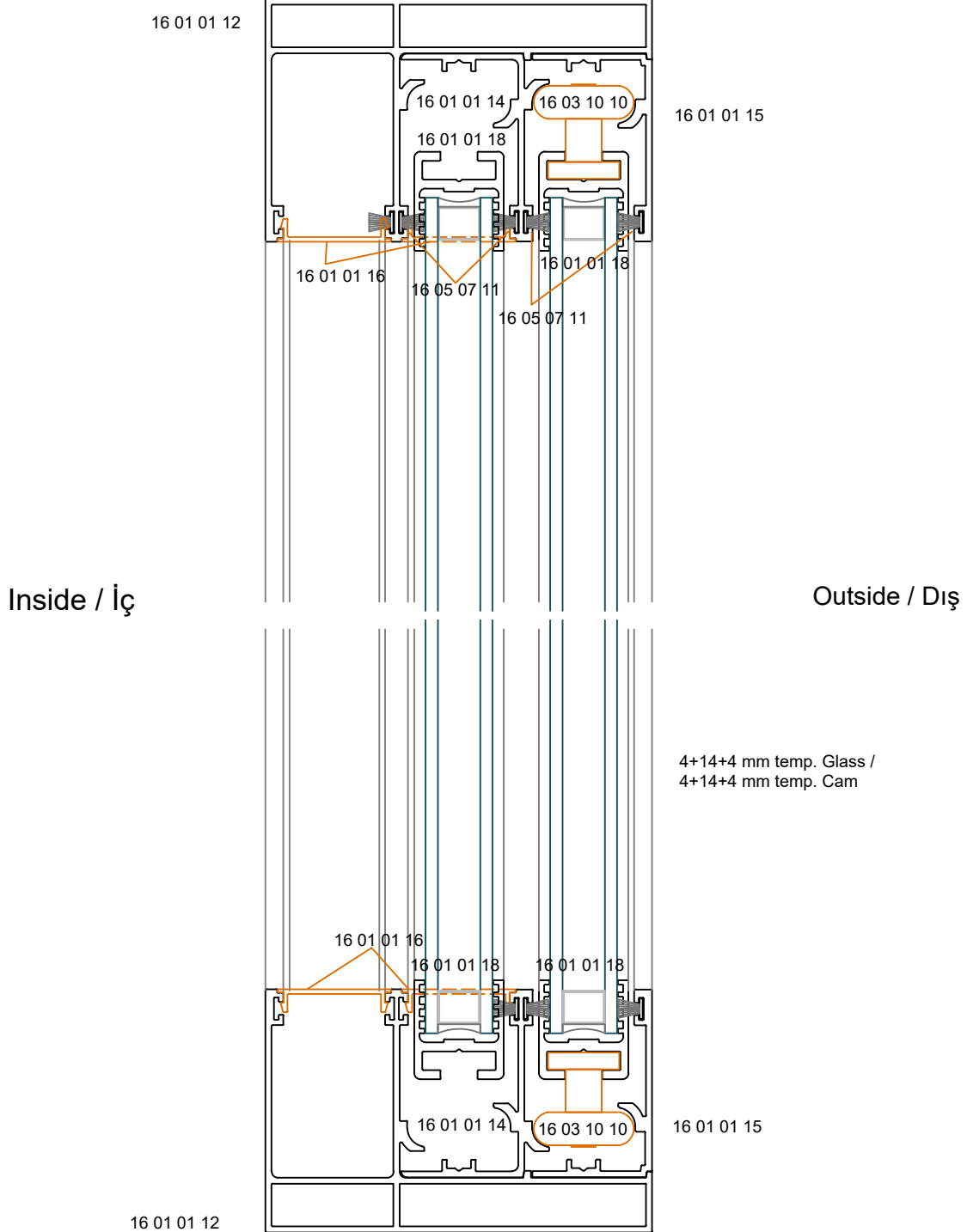

Top Section / Üstten Görünüş

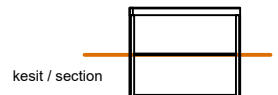

ASCENDO Section / Kesit



Scale / Ölçü: 1/2

Vertical Sliding System / Giyotin Sistem

ASCENDO

3 Elements at Top Stacking System /
3 Parça Üste Toplanan Sistem

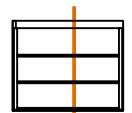
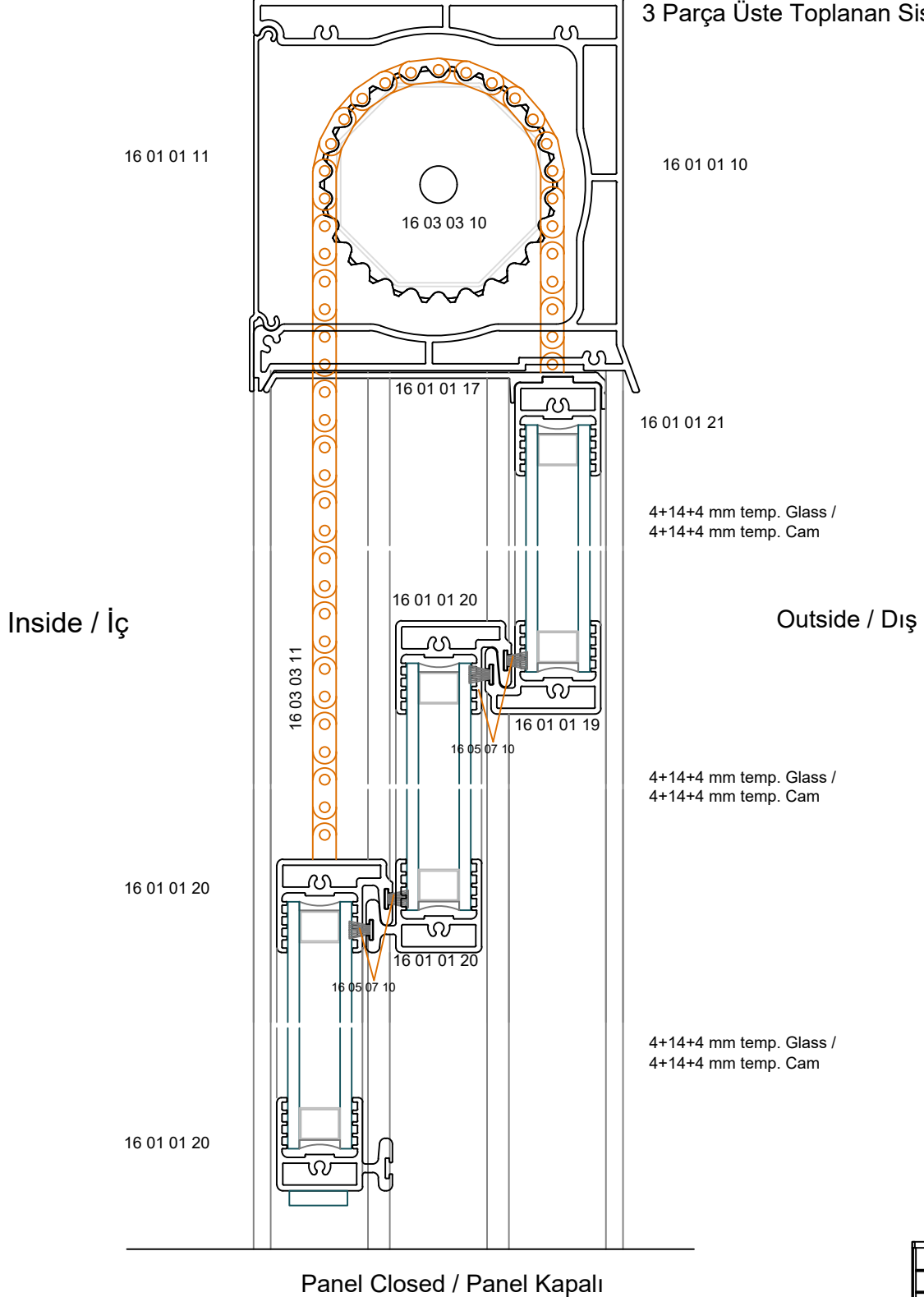

kesit / section

ASCENDO Section / Kesit

Scale / Ölçü: 1/2

Vertical Sliding System / Giyotin Sistem

ASCENDO

3 Elements at Top Stacking System /
3 Parça Üste Toplanan Sistem

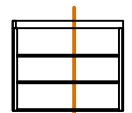
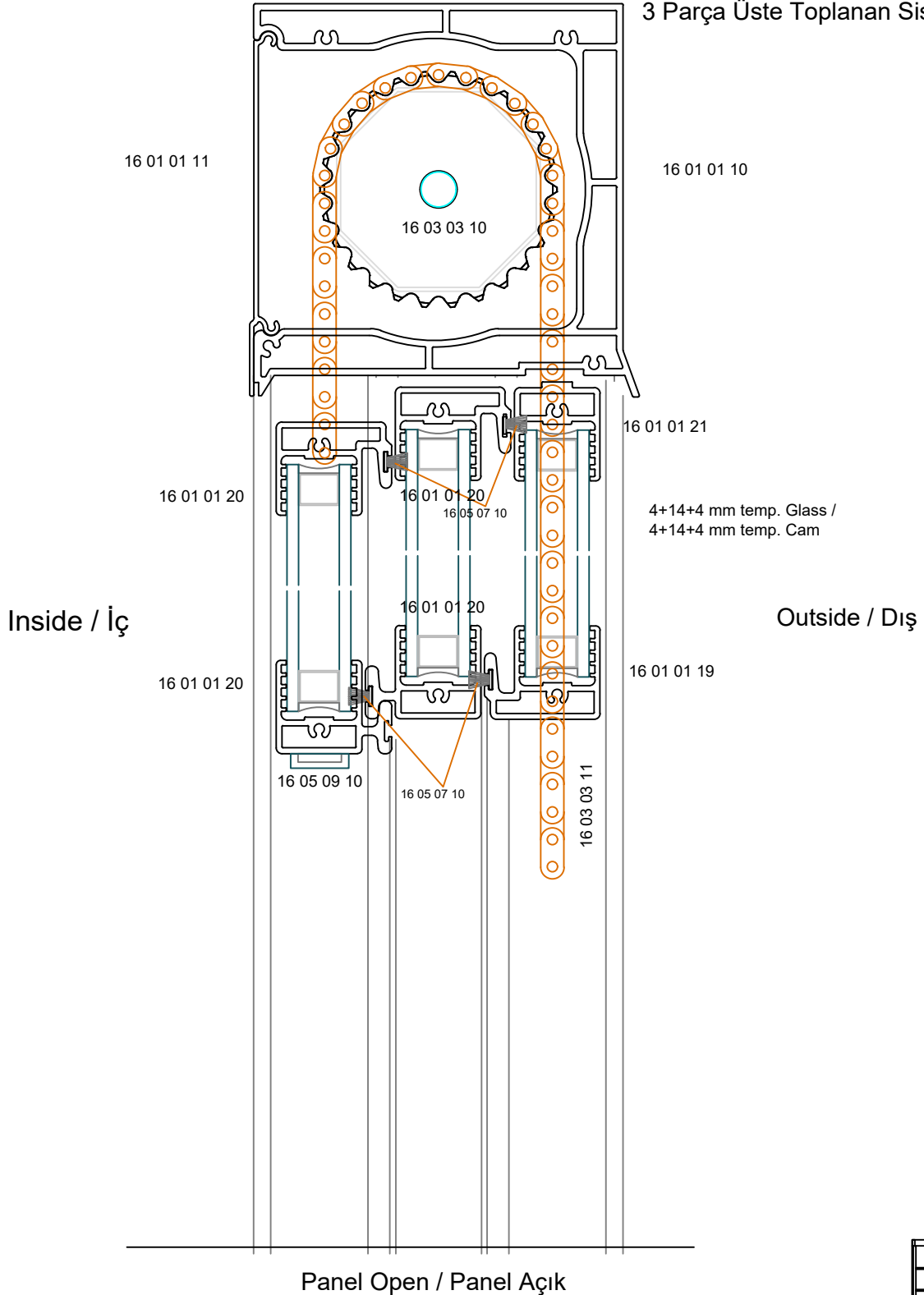

kesit / section

ASCENDO Top Section / Üst Kesit



Scale / Ölçü: 1/2

Vertical Sliding System / Giyotin Sistem

ASCENDO

3 Elements at Top Stacking System /
3 Parça Üste Toplanan Sistem

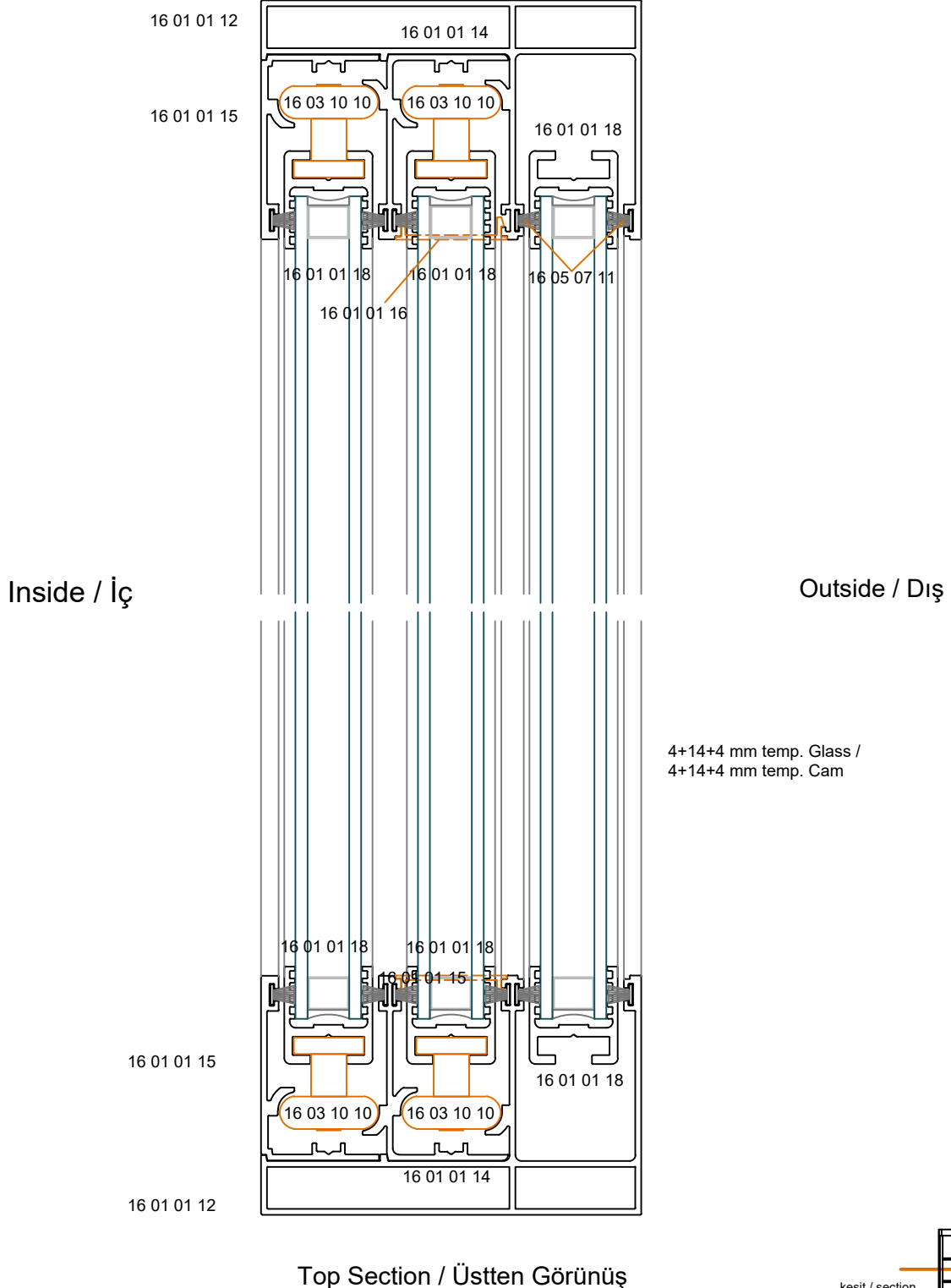

ASCENDO Section / Kesit



Scale / Ölçü: 1/2

Vertical Sliding System / Giyotin Sistem

ASCENDO

2 Elements at Top Stacking System /
2 Parça Üste Toplanan Sistem

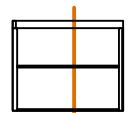
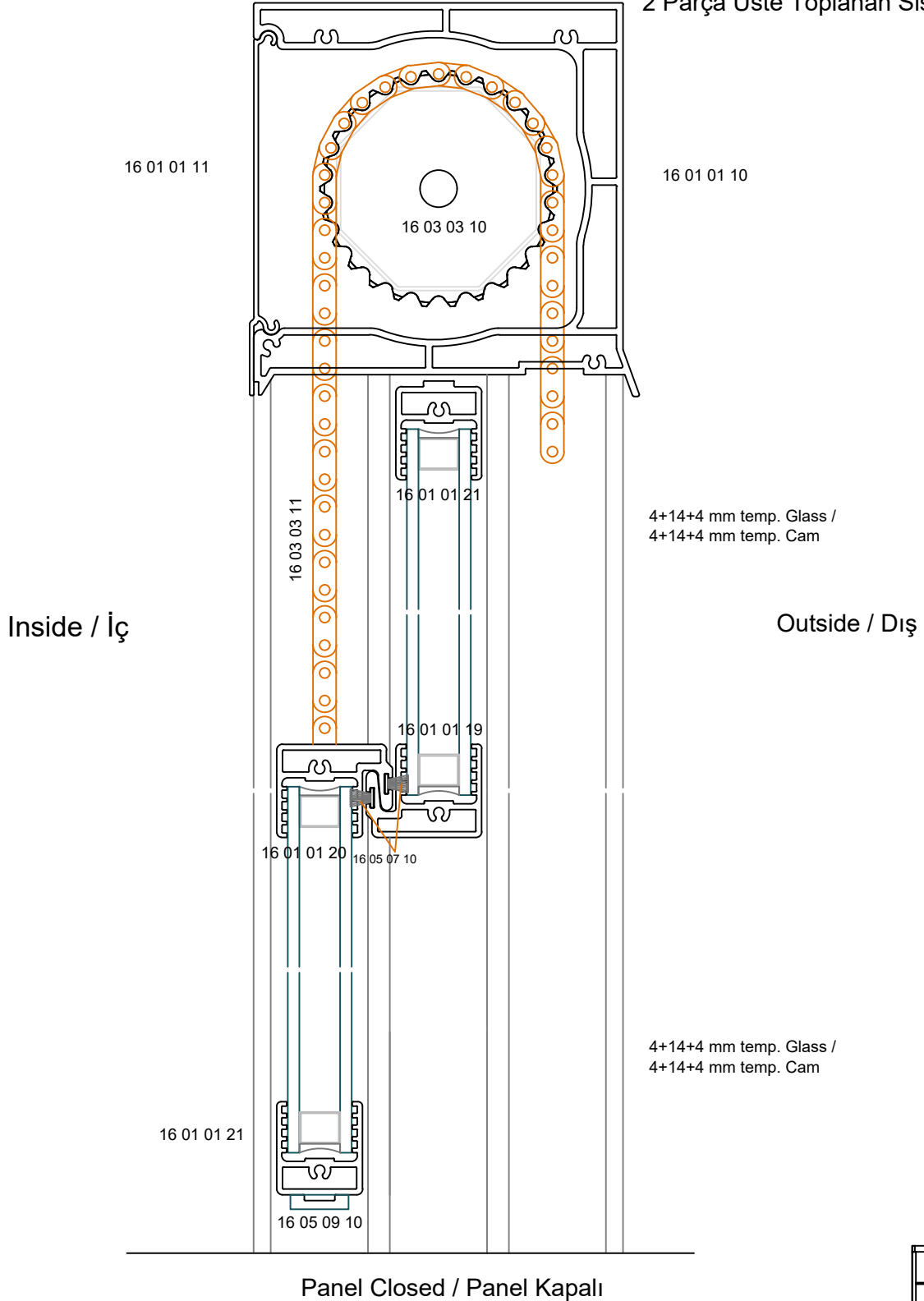

kesit / section

ASCENDO Section / Kesit



Scale / Ölçü: 1/2

Vertical Sliding System / Giyotin Sistem

ASCENDO

2 Elements at Top Stacking System /
2 Parça Üste Toplanan Sistem

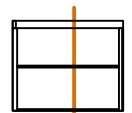
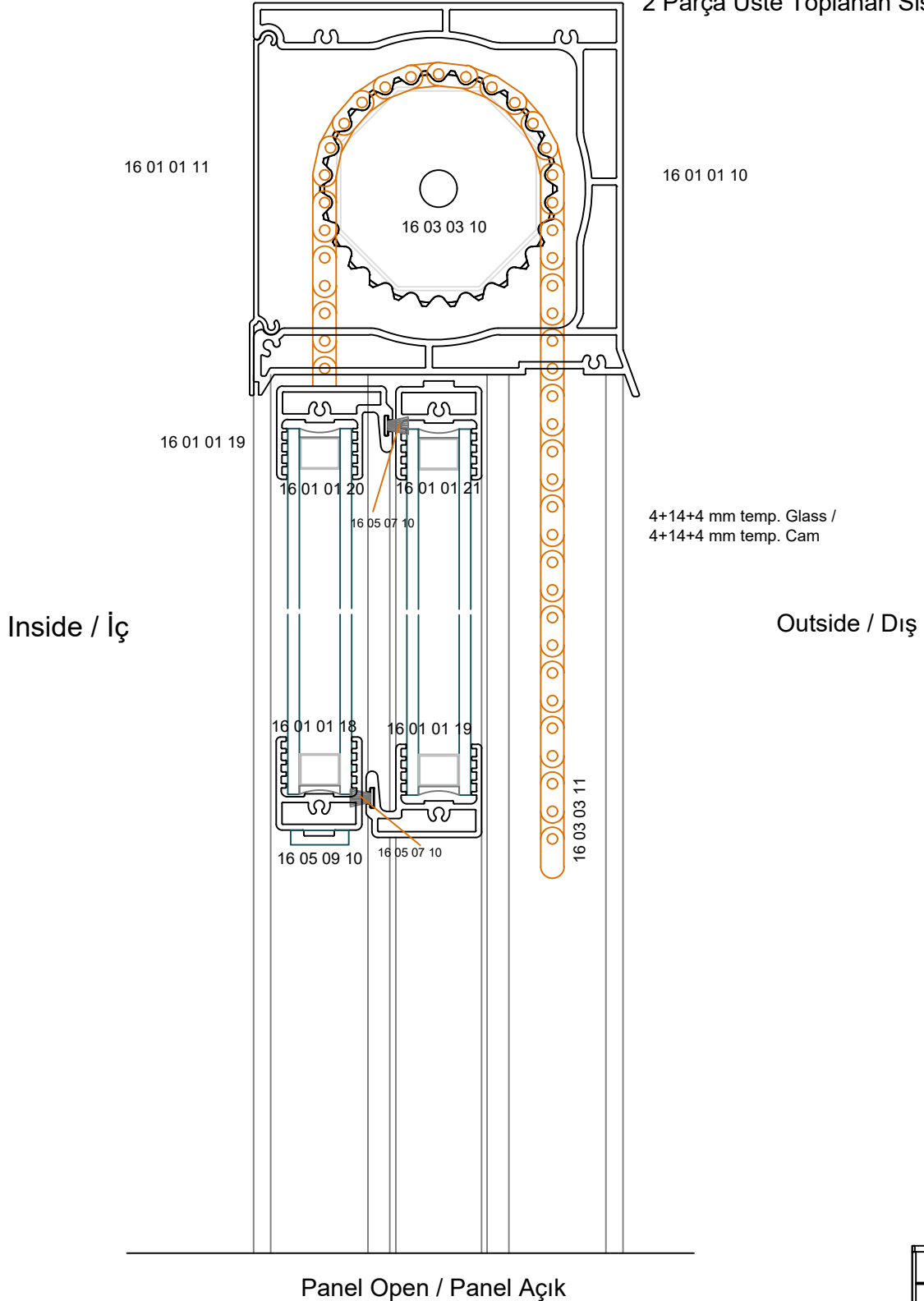

kesit / section

ASCENDO Top Section / Üst Kesit



Scale / Ölçü: 1/2

Vertical Sliding System / Giyotin Sistem

ASCENDO

2 Elements at Top Stacking System /
2 Parça Üste Toplanan Sistem

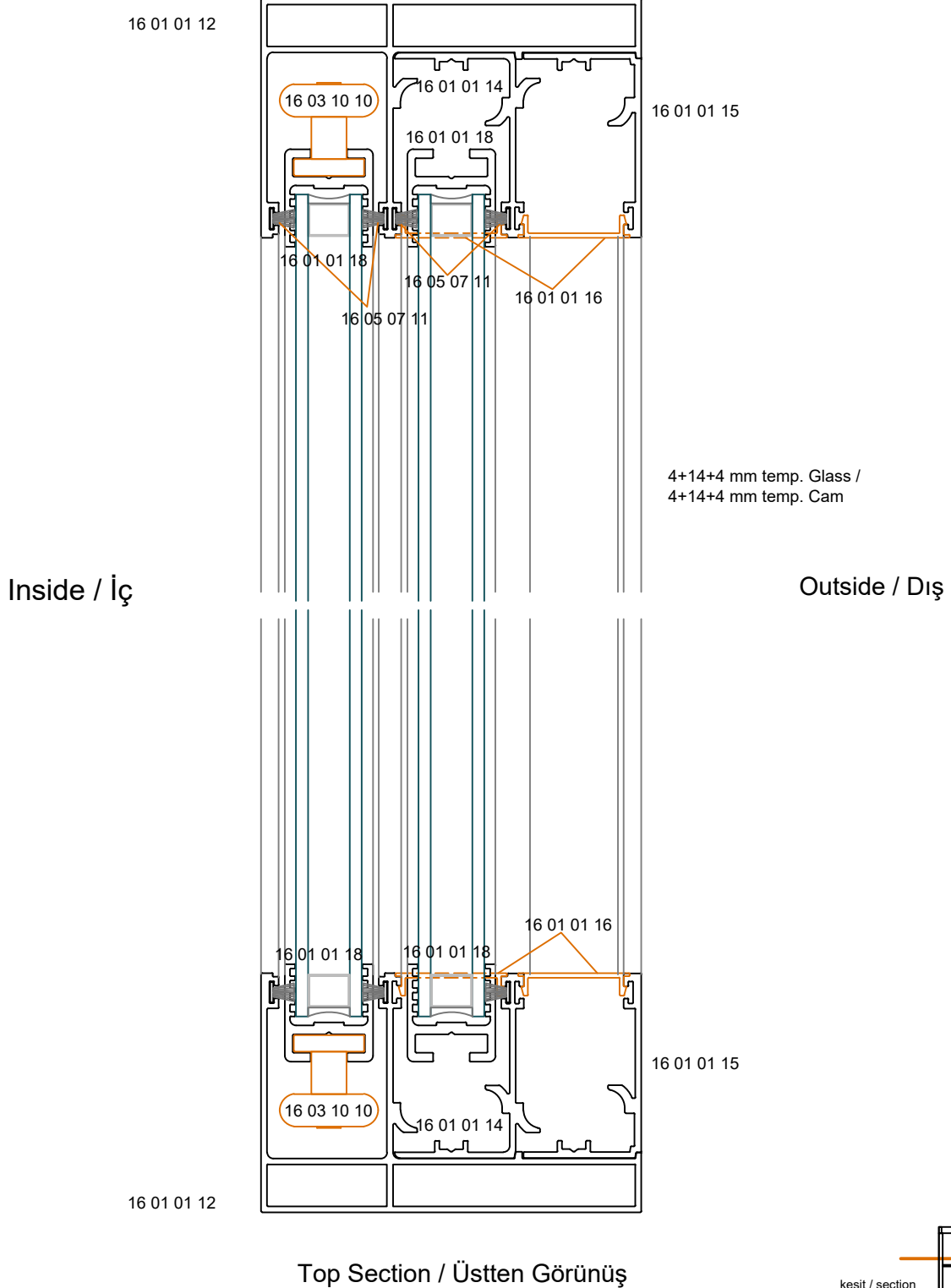

ASCENDO Front View / Ön Görünüş



Scale / Ölçü: 1/2

Vertical Sliding System / Giyotin Sistem

ASCENDO

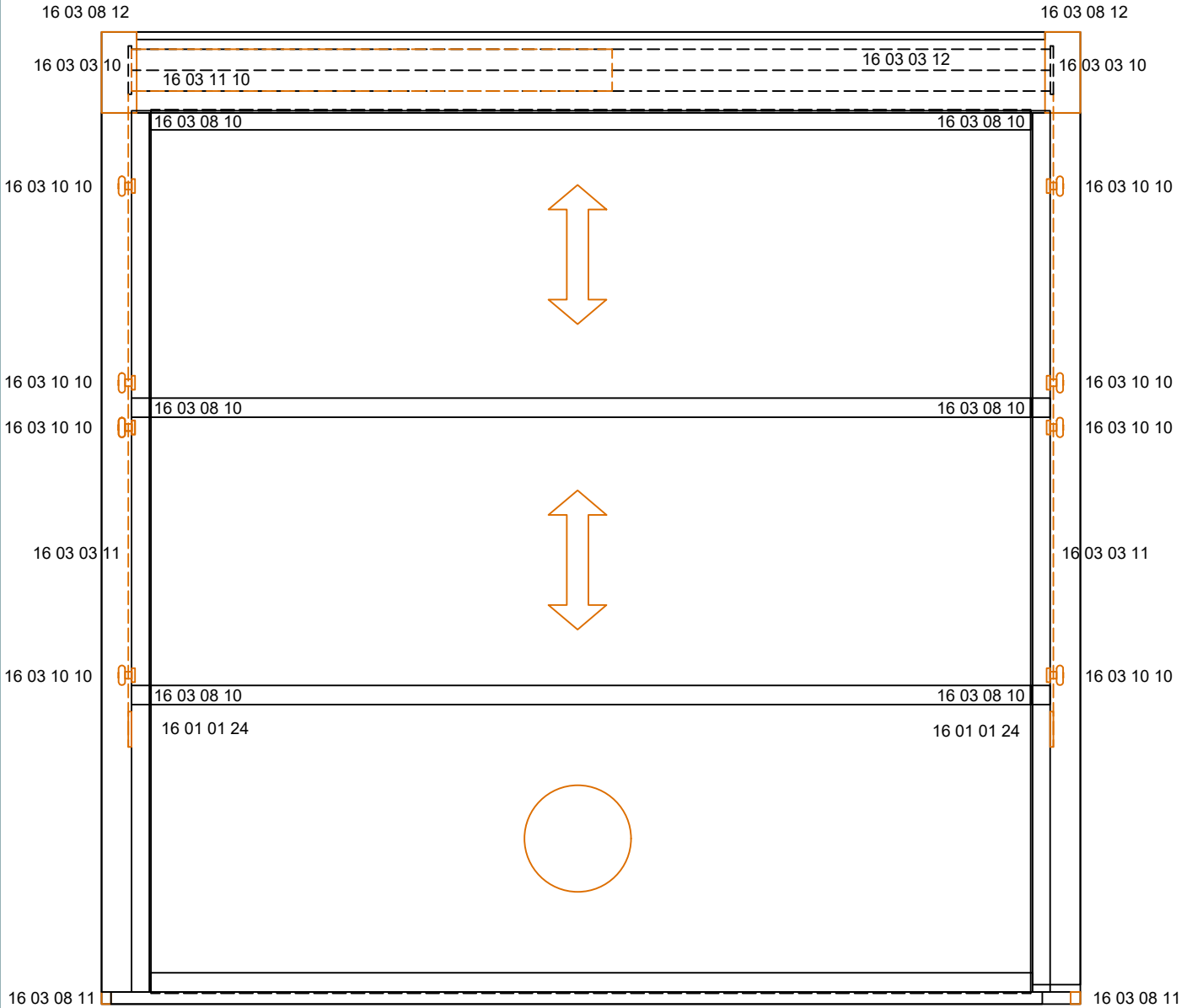



Istanbul Headquarter

Fikirtepe Mah. Özbey Cad. No:101, 34720 Kadıköy İstanbul / Turkey

T: +90 216 428 8428

Dubai Headquarter

Oud Metha Offices Building, R338 Umm Harair 2, Of:327 Dubai, United Arab Emirates

T: +971 52 839 57760

E: info@aluarc.com

www.aluarc.com



by Gürkan Building Elements